

Overview

GE intelligent addressable detectors are meticulously engineered to deliver high-performance features, superb reliability, and unbeatable quality. With their highly stable design, these detectors resist air movement caused by heating and air conditioning, making them reliable performers ideally suited to modern building interiors.

The installation and maintenance advantages of GE intelligent detectors add value throughout their service life. The twist-and-lock design makes short work of installation and maintenance operations. A plastic breakout on the detector housing optionally prevents removal from the base except with a special tool.

A bright, easy-to-see LED flashes red when the detector is in alarm, thus eliminating much of the guesswork when responding to front-panel indications.

- The **FX-HD** is a selectable rate of rise or fixed-temperature heat detector with an alarm threshold of 135° F (57° C).
- The **FX-PHD** houses an optical sensing chamber that detects smoke, as well as a fixed-temperature sensor that detects heat. The detector analyzes data from both sensors to determine when an alarm is initiated.
- The **FX-PD** houses an optical sensing chamber that detects smoke.
- The **FX-PDD** duct detector prevents smoke from circulating throughout the building – see *data sheet FX85001-0613*.

All detectors feature comprehensive self-diagnostic capability. FX-PD and FX-PHD optical detectors continuously adjust their sensitivity to compensate for changes in the environment such as the presence of dirt, smoke, temperature, and humidity. These detectors issue a dirty sensor warning when they reach their preset limit.

Standard Features

- Optical, heat, and multisensor models available
- Field replaceable optical chamber
- Highly stable design
- Compatible standard, relay, isolator, and audible bases
- Bases mount to standard North American two-gang or 4" square electrical boxes
- Twist-and-lock installation
- At-a-glance alarm indication
- Tamper-resistant feature
- Self diagnostic capability with on-board storage of results
- Optical detectors feature automatic rate compensated sensitivity adjustment, as well as dirty sensor warnings
- Manufactured to strict international ISO 9001 standards
- Assembled using surface mount technology for RF resistance
- Conformally coated components resist dust and humidity
- Automatic detector test
- Low Profile design

Addressable Detectors & Bases

Detectors: FX-PD, FX-PHD, FX-HD

Bases: B4U, RB4U, IB4U, SB4U



Detector details & Application

FX-PHD Optical/Fixed Temperature Detector

This intelligent analog device houses an optical sensing chamber that detects smoke, as well as a fixed-temperature sensor that detects heat. The detector analyzes data from both sensors to determine when an alarm is initiated.

The detector continuously adjusts its sensitivity based on fluctuating environmental conditions such as the presence of dirt, smoke, humidity, or changes in temperature, and notifies the panel of any changes in sensor sensitivity. When the detector has adjusted its sensitivity to its maximum limit, it issues a dirty sensor warning, allowing enough of a margin for maintenance personnel to clean the detector before it goes into trouble condition.

The FX-PHD is capable of performing comprehensive self-diagnostics and storing the results.

The FX-PHD combines the suitability of optical sensing for slow burning fires with the sensitivity of fixed-temperature detection for fast flaming fires to arrive at a solution that responds reliably to the widest range of fire types. A sophisticated algorithm processes data from both sensors over time so that an alarm is only reported when conditions precisely match the signature of a fire. This eliminates the shortcomings of single-sensor optical and heat detection, and significantly reduces the risk of nuisance alarms.

FX-HD Fixed Temperature Heat Detector

This intelligent analog device provides a 135°F (57°C) fixed-temperature heat sensor for the detection of heat due to fire. The heat sensor monitors the temperature of the air and determines whether an alarm should be initiated.

The FX-HD is capable of performing comprehensive self-diagnostics and storing the results.

Thanks to its advanced thermistor technology, the FX-HD detector is ideal for sensing fast, flaming fires and for applications where smoke detection is inappropriate. It is particularly well-suited to areas such as laundries and industries where fluctuations in ambient temperature is expected.

FX-PD Optical Smoke Detector

This intelligent analog device uses an optical sensing chamber to detect smoke. The detector analyzes data gathered by the sensor to determine when an alarm is initiated.

The detector continuously adjusts its sensitivity based on fluctuating environmental conditions such as the presence of dirt, smoke, humidity, or changes in temperature, and notifies the loop controller of any changes in sensor sensitivity. When the detector approaches its preset sensitivity threshold, it issues a dirty sensor warning, allowing enough of a margin for maintenance personnel to clean the detector before it goes into trouble condition.

The FX-PD is capable of performing comprehensive self-diagnostics and storing the results.

Thanks to its high-performance optical sensing chamber, the FX-PD responds quickly and reliably to a wide range of fire types, especially slow burning fires fuelled by combustibles typically found in modern multi-use buildings. The FX-PD detects extremely small particles and triggers an alarm at the first sign of smoke.

LED Indication

The detector provides a bicolor LED that shows its status.

- Normal: Green LED flashes
- Alarm/active: Red LED flashes

Module Addressing

Use a screwdriver to adjust the two rotary switches on the front of the module. Set the TENS rotary switch (0 through 12) for the 10s digit and the ONES rotary switch for the 0 through 9 digit.

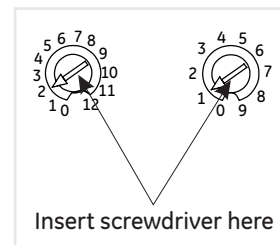

Example: device address 21, set TENS rotary switch to 2 and set the ONES rotary switch to 1.

Refer to the Specifications Table for available address numbers.

Detector Bases

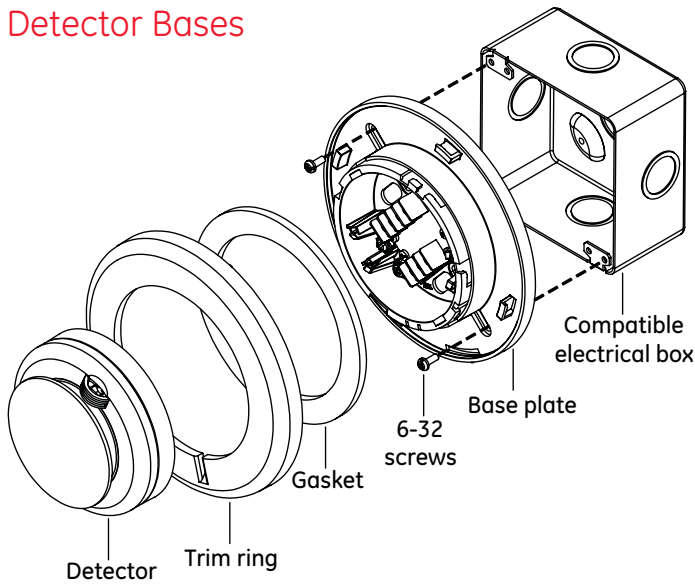

Connect the detector to the base by rotating the detector clockwise until it snaps into the locked position.

The head can be removed by turning it counterclockwise.

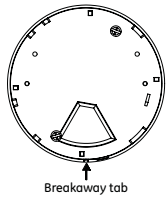

If the head must lock to the base, break away the locking tab shown below using a pair of pliers.

To then remove the detector head, insert a small screwdriver into the slot on the side of the base and press in while simultaneously turning the detector head counterclockwise.

B4U Standard Base

The B4U Analog Standard Detector Base features twist-and-lock detector installation and is compatible with with FX-Series analog detectors. The base does not require a separate address because it shares the address of the device it is connected to.

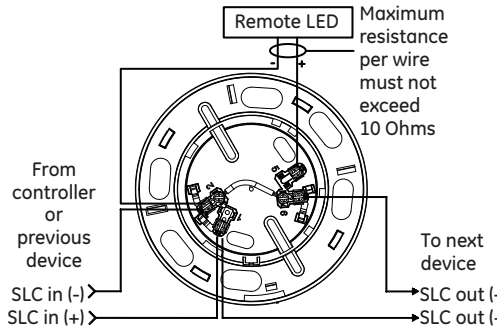

Term	Description	Term	Description
1	SLC in and SLC out (+)	4	Not used
2	SLC in (-)	5	Remote LED (+)
3	Not used	6	SLC out (-)
3	Not used	6	Remote LED (-)

Notes

1. Bases do not require separate addresses because they share the address of the device it is connected to.
2. Wire in accordance with NFPA 70, National Electrical Code.
3. Be sure to observe the polarity of the terminals on the terminal block as shown in the diagram.
4. Break wire run at each terminal. Do not loop signaling circuit field wires around terminals.

IB4U Isolator Detector Base

The IB4U Analog Isolator Detector Base is designed to prevent an entire communications loop from being disabled when a short circuit occurs. This is accomplished by isolating the part of the loop containing the short from the remainder of the circuit. These bases automatically restore the entire loop when the cause of the short circuit is corrected. The base can operate as an independent local alarm or as part of a zone.

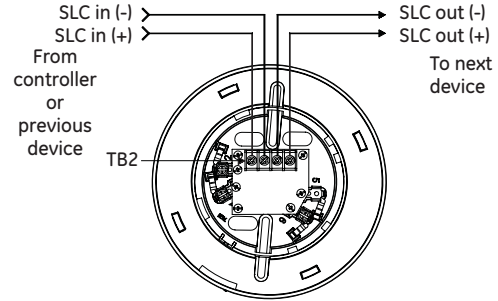

Term	Description
SLC in (+)	DATA + (IN)
SLC in (-)	DATA - (IN)
SLC out (+)	DATA + (OUT)
SLC out (-)	DATA - (OUT)

RB4U Relay Detector Base

The RB4U Analog Relay Detector Base is designed to add relay functionality to the listed compatible detectors. Form C latching relay contacts are included for the control of appliances such as door closers, fans, dampers, etc. The base can operate as an independent local alarm or as part of a zone.

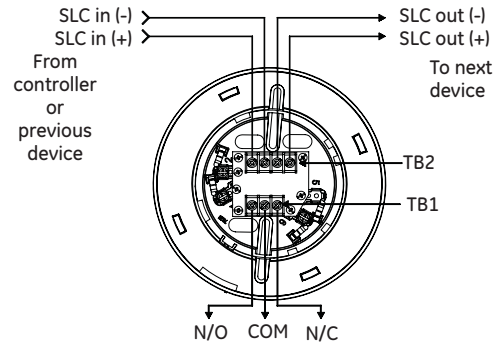

Term	Description	Term	Description
	N/O (Normally open)	SLC in (+)	DATA + (IN)
TB1	COM (Common)	SLC in (-)	DATA - (IN)
	N/C (Normally Closed)	SLC out (+)	DATA + (OUT)
		SLC out (-)	DATA - (OUT)

SB4U Audible (Sounder) Detector Base

The SB4U is designed to add an audible output function to compatible detectors. The base can operate as an independent local alarm, or as part of a zone or system alarm with synchronized audible output.

Depending on the system supporting the device loop, the base can operate as follows:

- It can follow the state of the device it supports
- It can be controlled and configured for other operating modes through programming.

The SB4U is field-configurable for output tone (steady or temporal) and output volume (low dBA or high dBA). The base must be connected to a continuous voltage whether the output tone is set to steady or temporal. The base does not require a separate address because it shares the address of the device it is connected to.

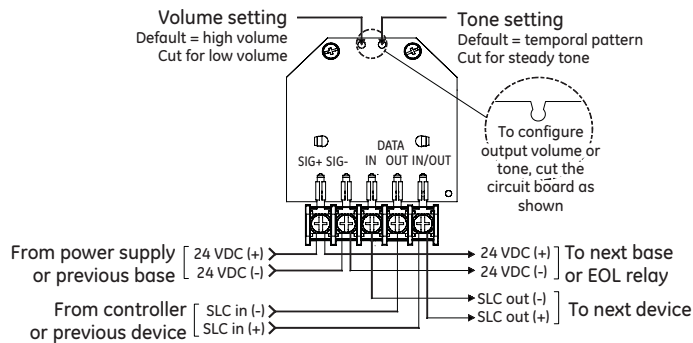

Sleeping rooms: In sleeping areas, the high dBA output and temporal tone settings must be used. However, if the FACP is producing the three-tone temporal evacuation signal, then the high dBA output and steady tone settings may be used.

AB4G-SB: When using the AB4G-SB box, install a reinforcing plate at every knockout used. (Reinforcing plates are included with the box.) Remove the knockout first, then slide the reinforcing plate into the plastic housing. After the plate is in place, install the conduit connector and nut.



Specifications, SB4U Audible Detector Base

Operating voltage	24 VDC or 24 VFWR, nominal
Operating current	See Table 1
Supervisory current	DC = 1.46 mA, FWR = 2.15 mA
Default settings	
Output volume	High dBA
Output tone	Temporal pattern
Sound level output	See Table 2
Temporal pattern	0.5 s on, 0.5 s off, 0.5 s on, 0.5 s off, 0.5 s on, 1.5 s off, repeat cycle
Operating environment	
Temperature	32 to 120°F (0 to 49°C)
Humidity	0 to 93% RH, noncondensing at 90°F (32°C)
Storage temperature	-4 to 140°F (-20 to 60°C)
Compatible detectors	FX-PD, FX-PHD, and FX-HD detectors
Compatible electrical boxes	North American 2-1/2 in. (64 mm) deep 2 gang box Standard 4" square box 1-1/2 in. (38 mm) deep box
Wire size	12, 14, 16, or 18 AWG wire (2.5, 1.5, 1.0, or 0.75 sq. mm) (Sizes 16 and 18 AWG are preferred)
Base diameter	6.0 in. (152 mm)
Height from box (including detector)	2.58 in. (66 mm)
Maximum distance from ceiling (wall mount)	12 in. (305 mm)

Operating current in mA (RMS)

Voltage	Low dBA	High dBA
16 VDC	17	28
24 VDC	24	41
33 VDC	31	52
16 VFWR	41	48
24 VFWR	51	60
33 VFWR	60	66

VDC = Volts direct current, regulated and filtered
VFWR = Volts full wave rectified

Sound level output (dBA)

Signal	Voltage	Low dBA	High dBA
Reverberant room per UL 464 [1]			
Temporal	16 VDC	71.3	77.2
	24 VDC	75.0	79.8
	33 VDC	77.7	81.5
Steady	16 VDC	75.8	80.5
	24 VDC	79.2	84.1
	33 VDC	82.0	86.0
Reverberant room per UL 268 [2]			
Temporal	16 VDC	77.3	83.2
	24 VDC	81.0	85.8
	33 VDC	83.7	87.5
Steady	16 VDC	81.8	86.5
	24 VDC	85.2	90.1
	33 VDC	88.0	92.0

dBA = Decibels, A-weighted

[1] For UL 464 applications, low dBA settings are for private mode only

[2] For UL268 applications, high setting must be used for evacuation

Specifications, Detectors

	FX-PHD	FX-PD	FX-HD
Air velocity	0 to 5,000 ft/min (0 to 25.39 m/s)		N/A
Smoke sensitivity range	0.67% - 3.66%		
ULI fixed-temp alarm rating	135°F (57°C)	N/A	135°F (57°C)
ULC fixed-temp alarm rating	140°F (60°C)		140°F (60°C)
Maximum Spacing	N/A		50 ft (15 m) centers
Rate-of-Rise	N/A		N/A
Operating voltage	15.2 to 19.95 VDC		
Normal operating current	45 µA, average		
Alarm current	Automatic		
Environmental compensation	Automatic		
Compatible bases	B4U Standard, RB4U Relay, IB4U Isolator, SB4U Audible		
Maximum distance from ceiling wall-mounted	12 in (305 mm)		
Storage temperature	-4 to 140°F (-20 to 60°C)		
Operating environment	Temperature: 32 to 120°F (0 to 49°C); Humidity: 0 to 93% RH, noncondensing at 90°F (32°C)		
Agency listings	Meets UL 268, ULC-S529-02, UL 521, ULC-S530-M91, NFPA 72, and CAN/ULC S524-01	Meets UL 268, ULC-S529-02, NFPA 72, and CAN/ULC S524-01	Meets UL 521, ULC-S530-M91, NFPA 72, and CAN/ULC S524-01

Specifications, Bases

	B4U Standard Base	IB4U Isolator Detector Base	RB4U Relay Detector Base
Operating environment	32 to 120°F (0 to 49°C)		
Temperature	0 to 93% RH, noncondensing at 90°F (32°C)		
Humidity	-4 to 140°F (-20 to 60°C)		
Storage temperature range	FX-PD, E-PD, FX-PHD, E-PHD, FX-HD, E-HD, FX-PD, FX-PHD, and FX-HD detectors		
Compatible detectors	North American 2-1/2 in. (64 mm) deep 2 gang box		
Compatible electrical boxes	Standard 4 in. square box 1-1/2 in. (38 mm) deep box		
Wire size	12, 14, 16, or 18 AWG wire (2.5, 1.5, 1.0, or 0.75 sq. mm) (Sizes 16 and 18 AWG are preferred)		
Base diameter	6.0 in. (152 mm)		
Height from box (including detector)	2.08 in. (53 mm)		2.57 in. (65 mm)
Maximum distance from ceiling (wall mount)	12 in. (305 mm)		

Ordering Information

Model	Description	Ship Wt.: lb. (kg)
FX-PHD	Intelligent Analog Optical/Fixed Temperature Detector	0.25 (0.11)
FX-PD	Intelligent Analog Optical Smoke Detector	0.25 (0.11)
FX-HD	Intelligent Analog Fixed Temperature Heat Detector	0.25 (0.11)
FX-PDD	Intelligent Duct Detector (see data sheet 85001-0613)	2.4 (1.1)
B4U	Standard Base	0.11 (0.05)
RB4U	Relay Detector Base	0.11 (0.05)
IB4U	Isolator Detector Base	0.11 (0.05)
SB4U	Audible (Sounder) Detector Base	0.11 (0.05)
AB4G-SB	Surface Box for Audible Base	1.0 (0.45)
RLED	Remote alarm LED, use with standard base only	0.2 (.09)

GE Security

U.S.
T 888-GESECURITY
F 503-691-7566

Canada
T 519 376 2430
F 519 376 7258

Asia
T 852 2907 8108
F 852 2142 5063

Latin America
T 305 593 4301
F 305 593 4300

www.gesecurity.com/fireworx

© 2009 General Electric Company
All Rights Reserved



imagination at work